

A Strong Heart for a Stronger System

Shinhoo

Solutions for **Wall Hung Boiler**

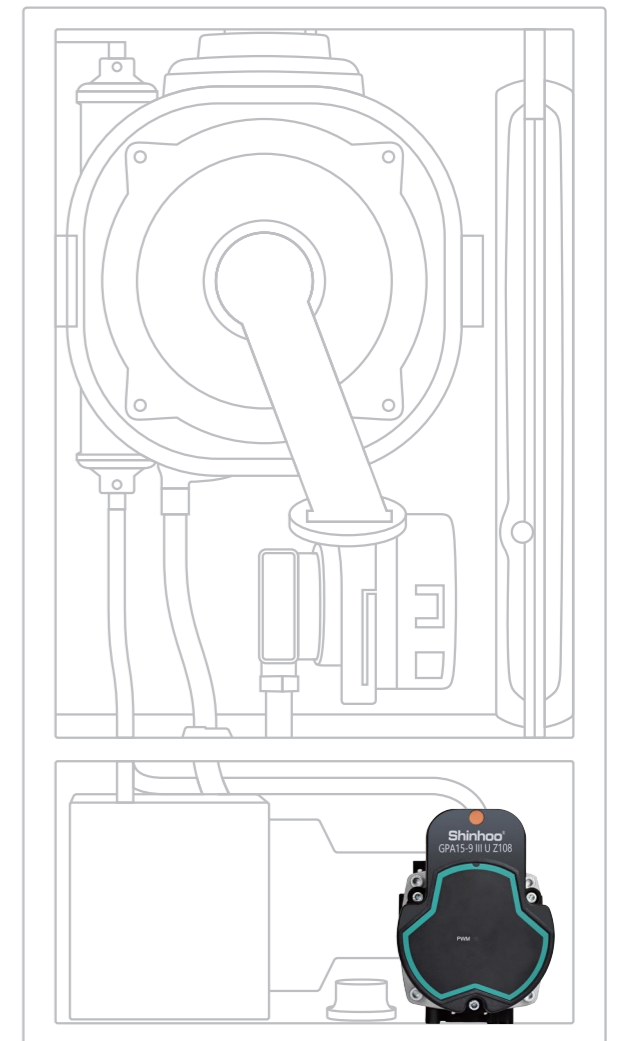

ANHUI SHINHOO CANNED MOTOR PUMP CO., LTD.

The wholly-owned subsidiary of Zhejiang Dayuan Pump Industry Co., Ltd. (Shanghai Stock Exchange: 603757). Upholding the Group's strategy vision of "Wholeheartedly dedicated to pump excellence, we build a century enterprise," the company specializes in the R&D, manufacturing, and sales of commercial and residential canned motor pumps. Its products are widely applied across multiple fields including HVAC, building water supply, hot water systems, and equipment room cooling, providing leak-free fluid transfer system solutions to diverse industrial clients.

Address: No. 780 Mingchuan Road, High-Tech Zone, Hefei City, Anhui Province
china@shinhoodump.com
<https://www.shinhoodump.com>

Printed: December 2025



ANHUI SHINHOO CANNED MOTOR PUMP CO., LTD.

Wall Hung Boiler Circulator





Shinhoo wall hung boiler circulator is specially designed to provide customized design and comprehensive solutions with low noise and intelligent control for boiler heating systems.

Shinhoo wall hung boiler circulator is suitable for various systems including conventional boiler, atmospheric flue gas recovery condensing boiler and fully premixed condensing wall hung boiler.

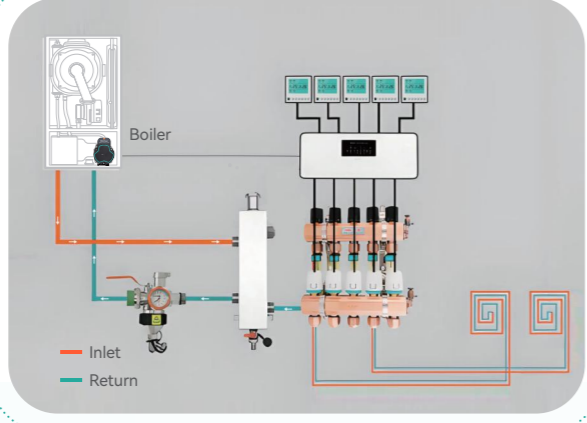
Benefits

-  Compact structure
-  Multi-speed integration
-  Low noise (Min. 26dB(A))



-  Canned structure, no leakage
-  Long service life, maintenance-free
-  Multi-interface integration, simplified waterways
-  Customisation available

Customized housings



Circulator for wall hung boilers

GPD Series (Standard efficiency)

Features



- Single-phase asynchronous canned motor
- Multi-speed available (5/6/7m)
- Integrated and automatic air vent

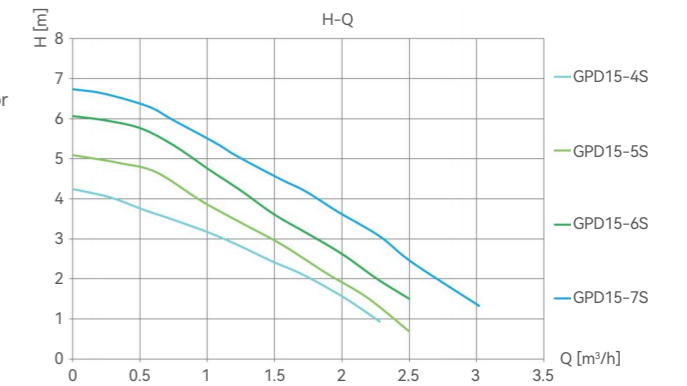

GPA-II Series (High efficiency)

Features



- Permanent magnet synchronous motor
- Multi-speed integrated (3 speed + Auto)
- Integrated and automatic air vent
- High efficiency, $EEL \leq 0.23$
- Variable speed control + PWM with power feedback

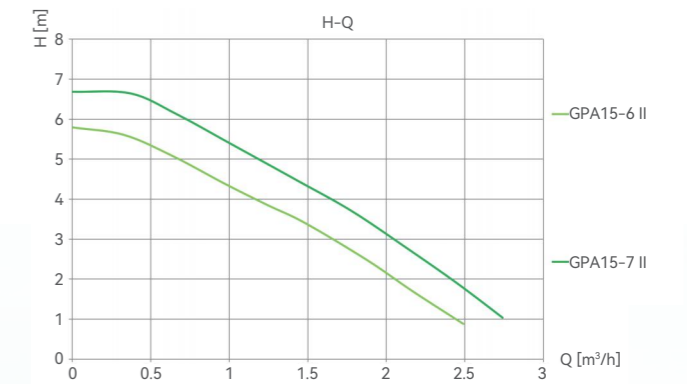

GPA-III Pro Series (High efficiency)

Features



- Permanent magnet synchronous motor
- Manually self-control (4-speed + PWM)
- Integrated and automatic air vent
- High efficiency, $EEL \leq 0.20$
- PWM control with power feedback
- Suitable for maximum 36KW boiler

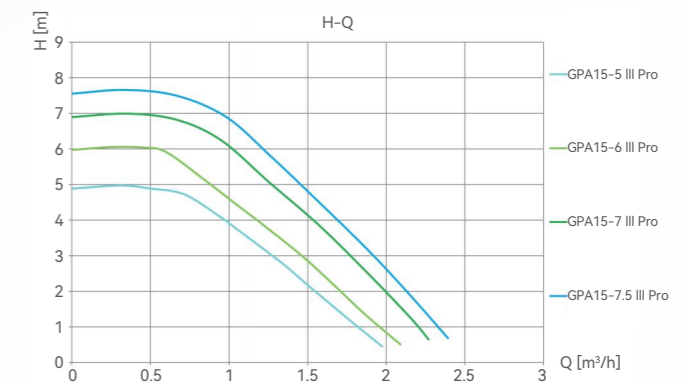

GPA-III U Series (High efficiency)

Features



- Permanent magnet synchronous motor
- Integrated and automatic air vent
- High efficiency, $EEL \leq 0.20$
- PWM control with flow feedback
- LIN control with flow & head & power & rotational speed feedback
- Enhanced EMC capacity, not disturbed by ignition
- No flow reduced @ min 170V
- Suitable for maximum 45KW boiler

